

CUSTOMER DRAWING

REV.	ECO. NO.	DESCRIPTION
A	DWG. REL.	APPROVED
B	ES060203	
C	ES070208	
D	ES101218	
E	ES140324	
F	ES160527	ADD THE HOLE ON THE STRIP

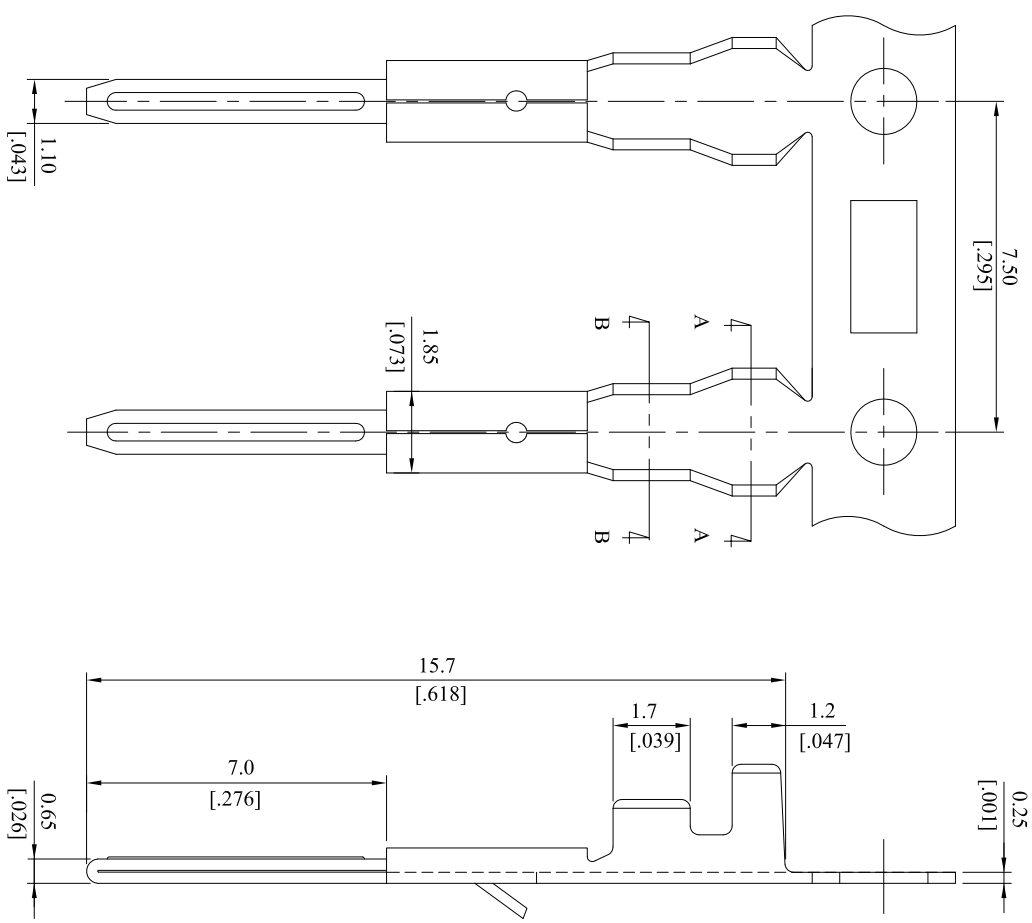

*** 5713 Series ***

Material:

* Contact : Phosphor Bronze

* Plating : Tin plated 120µ " min over 30µ " min. nickel overall

<p>LEOCO CORPORATION http://www.leoco.com.tw</p>		<p>LEOCO CORPORATION</p>	
<p>APPROVED BY: Chard</p>	<p>DATE: 2016.6.3</p>	<p>TITLE: Terminal</p>	<p>PART NO.: 5713TPB0000</p>
<p>CHECKED BY: Angel</p>	<p>DATE: 2016.6.3</p>	<p>DRAWN BY: Tess</p>	<p>DATE: 2016.6.3</p>
<p>1 PLACE ± 0.30</p>	<p>2 PLACES ± 0.20</p>	<p>3 PLACES ± 0.10</p>	<p>4 PLACES ± 0.04</p>
<p>mm [inch]</p>	<p>mm</p>	<p>inch</p>	<p>mm</p>
<p>TOLERANCE UNLESS OTHERWISE SPECIFIED</p>			
<p>ANGULAR ±1°</p>			
<p>SIZE: A3</p>	<p>SCALE: 1:1</p>	<p>DRAWING NO.: 571301S</p>	<p>REV.: F</p>
		<p>SHEET: 1 OF 1</p>	